

## GPON OLT B+ Optical Module

### CLGPONOLTB+

### CLGPONOLTB+I

#### Product Features

- Support ITU-T G.984.2 GPON OLT B+ application
- Single fiber bi-directional data links with symmetric 2.488Gbps Tx and 1.244Gbps Rx
- 1490nm continuous-mode transmitter with DFB LD
- 1310nm burst-mode receiver with APD-TIA
- 2-wire interface for integrated digital diagnostic Monitoring
- Receiver RESET, Signal Detect, RSSI function indication (RESET, RX\_SD, RSSI)
- SFP package with SC/UPC receptacle optical interface
- Single +3.3V power supply
- Operation case temperature -40~85°C for industrial and 0~70°C for commercial
- RoHS6 compliance

#### Operating Condition

Parameter	Unit	Min.	Typical	Max.
Storage Temperature	°C	-40		85
Operating Case Temp for C-temp	°C	0		70
Operating Case Temp for I-temp	°C	-40		85
Power Supply Voltage	V	3.15	3.3	3.45
Supply Current	mA			500
Bit Rate for Tx	Gbps		2.488	
Bit Rate for Rx	Gbps		1.244	

#### Characteristics

All performance is specified at whole working temperature and conditions

Parameter	Unit	Min.	Typical	Max.
<b>Transmitter</b>				
TX Central Wavelength	nm	1480	1490	1550
Spectral Width (-20dB)	nm			1
Side Mode Suppression Ratio (SMSR)	dB	30		
Mean Launched Power	dBm	1.5		5
Mean Launched Power (TX Off)	dBm			-45
Extinction Ratio	dB	8.2		
Optical Return Loss Tolerance	dB	-15		
Transmitter and dispersion Penalty	dB			1

Transmitter Mask(PRBS2 <sup>23</sup> -1@2.488G)	Compliant With ITU-T G.984.2			
<b>Receiver</b>				
Receive Wavelength	nm	1290	1310	1330
Sensitivity (PRBS2 <sup>23</sup> -1@1.244G,ER=10,BER<10 <sup>-10</sup> )	dBm			-28
Overload (PRBS2 <sup>23</sup> -1@1.244G,ER=10,BER<10 <sup>-10</sup> )	dBm	-8		
Receiver Burst Mode Dynamic Range	dB	15		
Damage Threshold for Receiver	dBm	5		
SD Assert Level	dBm			-30
SD De-assert Level	dBm	-45		
SD Hysteresis	dB	0.5		6
WDM Filter isolation to 1550nm	dB	38		
WDM Filter isolation to 1650nm	dB	35		
<b>Electrical Interface Characteristics</b>				
Data Input Swing Differential/TX	mV	200	-	2000
Data Output Swing Differential/RX	mV	400		1600
Date Differential Impedance	Ω	90	100	110
LVTTL Output High	V	2.4		V <sub>cc</sub>
LVTTL Output Low	V	0		0.4
LVTTL Input High	V	2.0		V <sub>cc</sub> +0.3
LVTTL Input Low	V	0		0.8
<b>Timing Characteristics</b>				
Guard Time (T <sub>g</sub> )	ns	25.6		
Reset Pulse Width (T <sub>r</sub> )	ns			12.8
Reset Delay (T <sub>rd</sub> )	ns			12.8
Receiver Preamble Time (T <sub>p</sub> )	ns			140
SD Assert Time (T <sub>SDA</sub> )	ns			100
SD De-assert Time (T <sub>SDD</sub> )	ns			12.8
RSSI Trigger Delay (T <sub>td</sub> )	ns	25		
RSSI Trigger Pulse Width (T <sub>w</sub> )	ns	500		
Internal I2C Delay (T <sub>I2C</sub> )	us			500

## Timing Sequence for RSSI

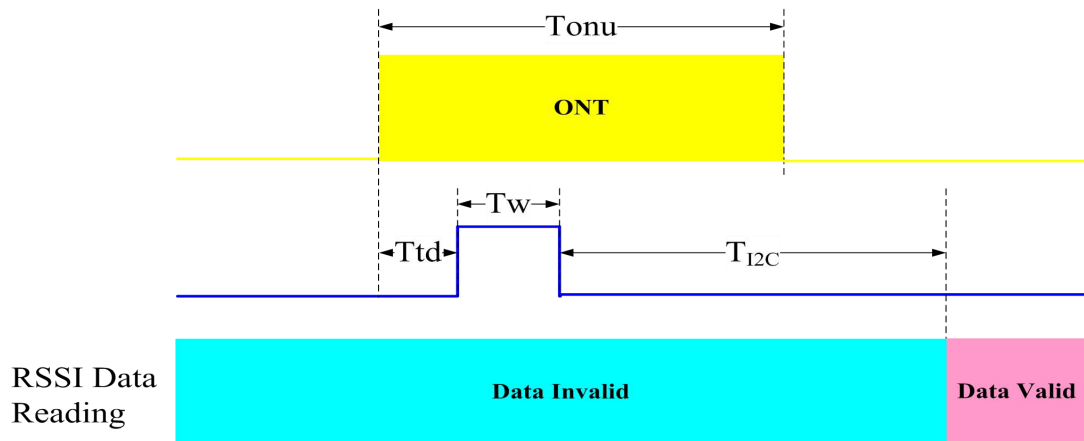

## Timing Sequence for Ranging Mode

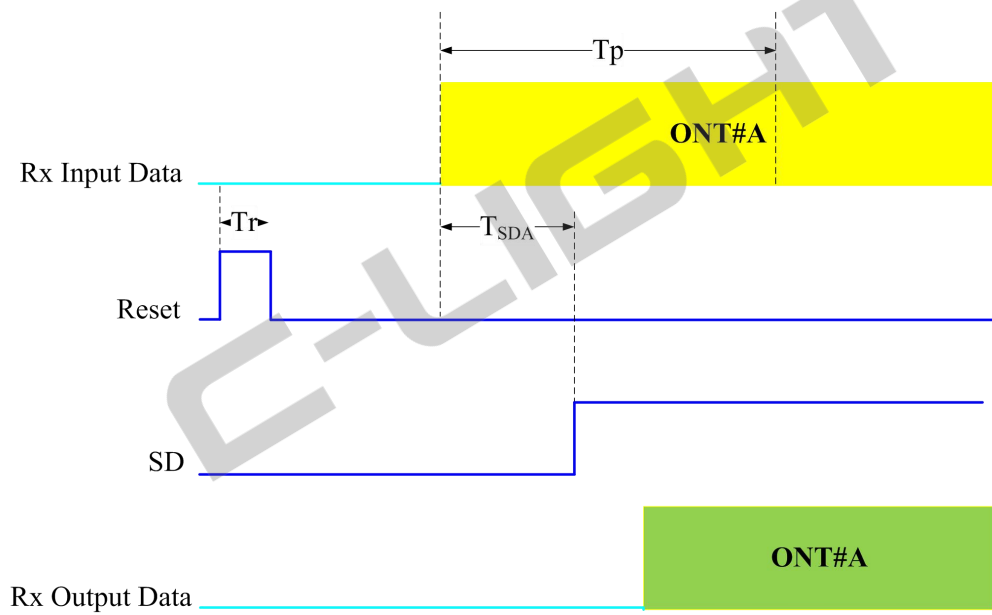

## Timing Sequence for Working Mode

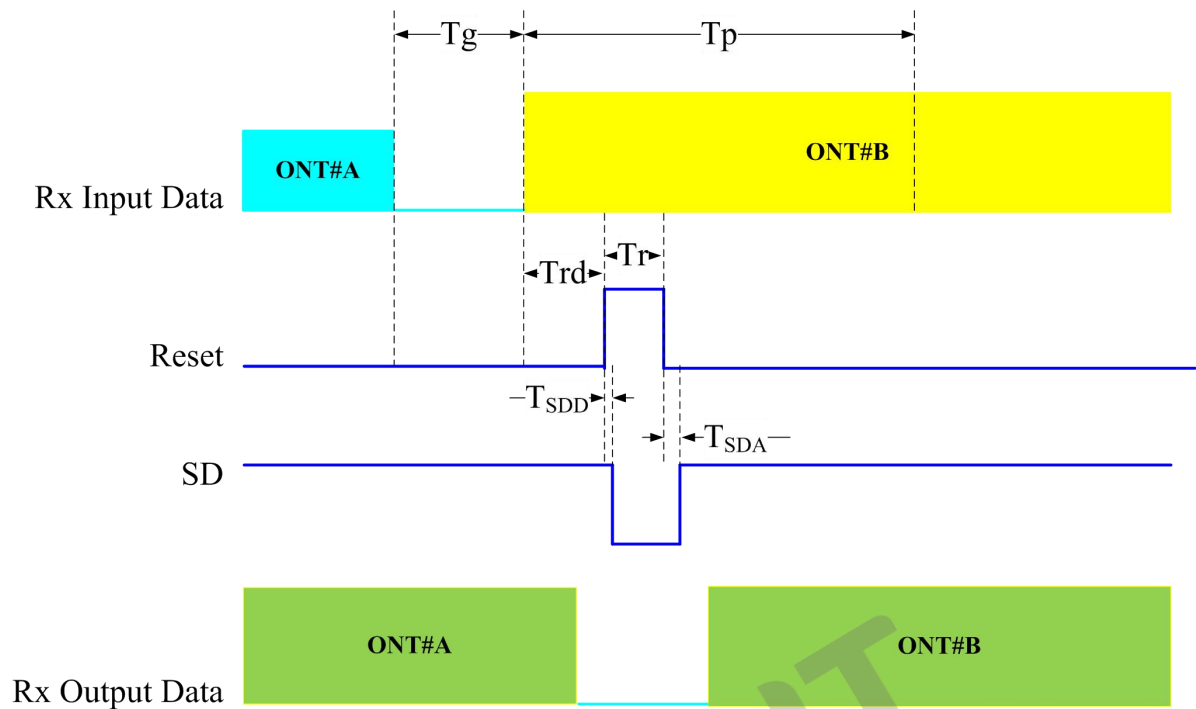

## Pin Definitions

Pin No.	Symbol	Level / Logic	Description
1	VeeT		Module Transmitter Ground
2	Tx_Fault	LVTTL-O	Module Transmitter Fault
3	Tx_DIS	LVTTL-I	Laser output is disabled when this pin is asserted high or left unconnected
4	SDA	LVTTL-I	2-Wire Serial Interface Data Line
5	SCL	LVTTL-I/O	2-Wire Serial Interface Clock
6	MOD_ABS	LVTTL-O	Module Absent, connected to ground in the module
7	RX_Reset	LVTTL-I	Receiver RESET signal
8	RX_SD	LVTTL-O	Receiver Signal Detected Indication
9	RSSI_TRIG	LVTTL-I	Receiver RSSI Trigger signal
10	VeeR		Module Receiver Ground
11	VeeR		Module Receiver Ground
12	RD-	LVPECL-O	Receiver Inverted Data Output
13	RD+	LVPECL-O	Receiver Non-Inverted Data Output
14	VeeR		Module Receiver Ground
15	VccR		Module Receiver 3.3V Supply
16	VccT		Module Transmitter 3.3V Supply
17	VeeT		Module Transmitter Ground
18	TD+	LVPECL-I	Transmitter Non-Inverted Data Input

19	TD-	LVPECL-I	Transmitter Inverted Data Input
20	VeeT		Module Transmitter Ground

## Recommended Interface Circuit

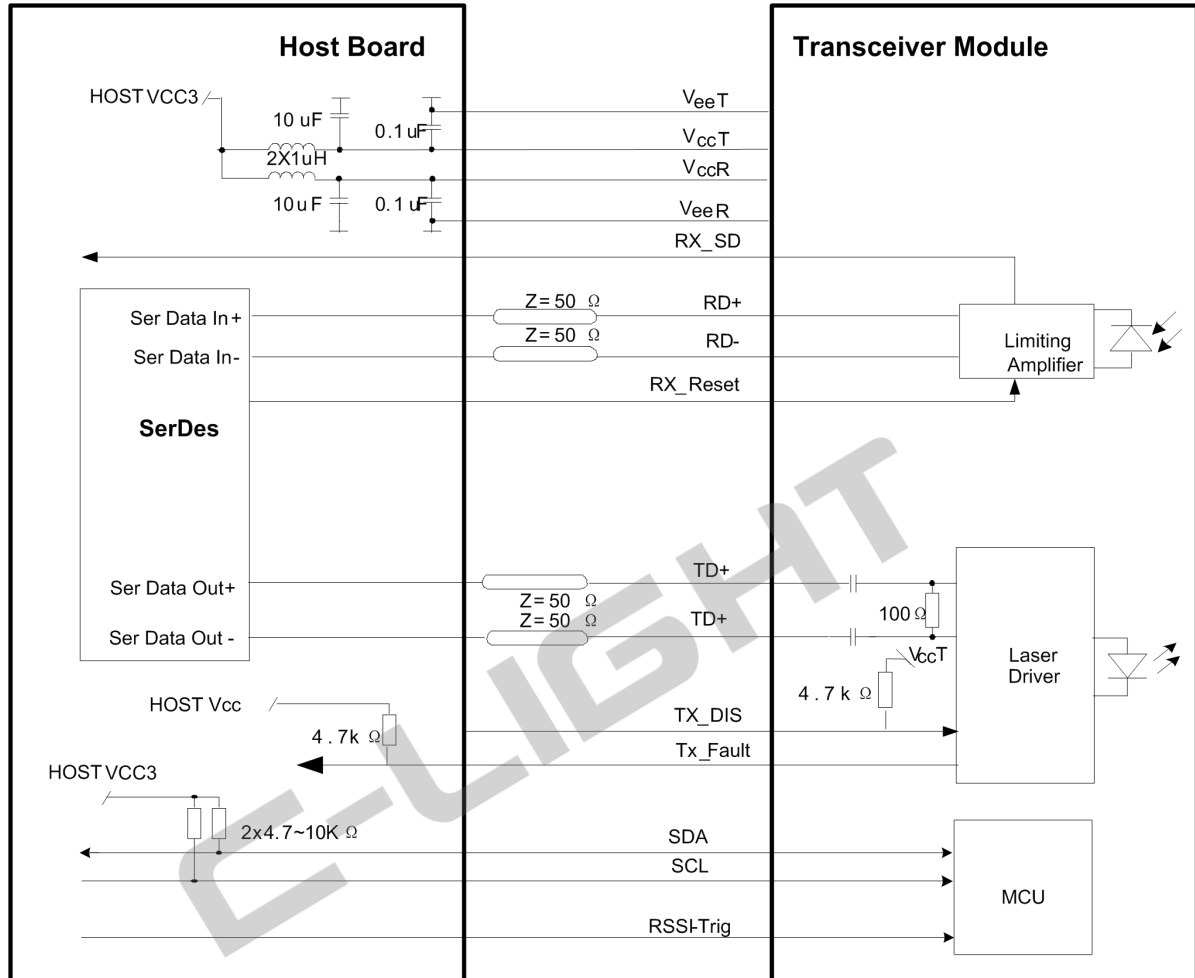

## Mechanical Diagram

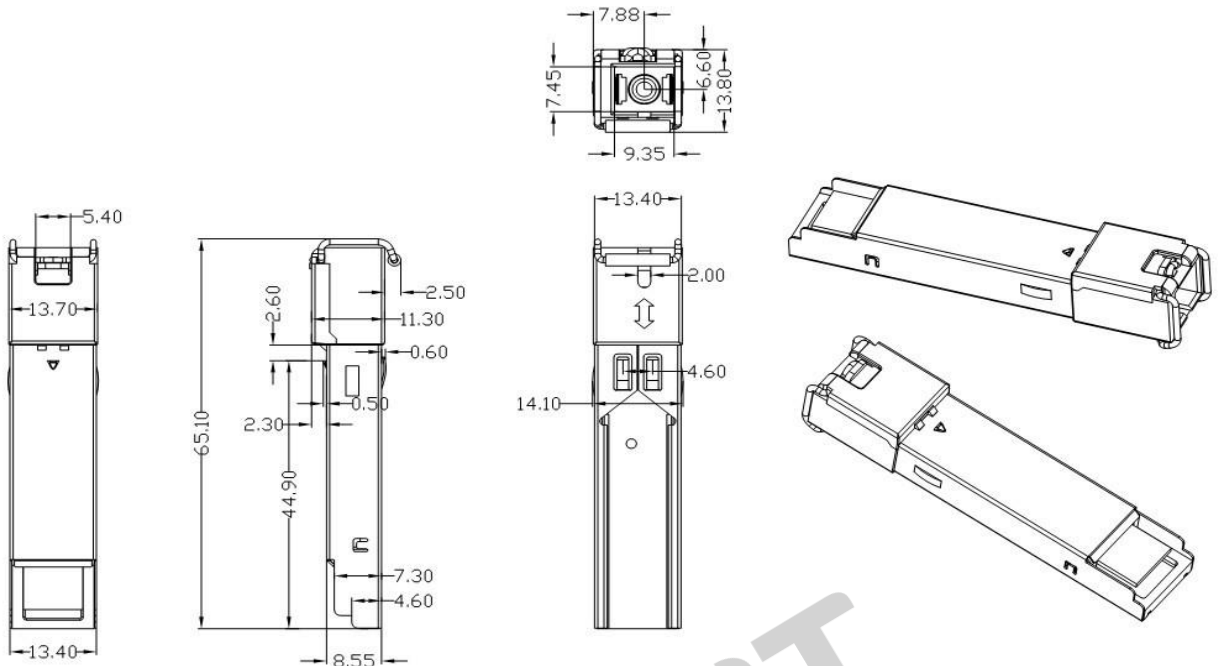

## EEPROM Memory Map – Page A0h

Addr.(Dec)	Size(byte)	Name of field	Default Value(Hex)	Description
0	1	Identifier	03	Pluggable transceiver
1	1	Extended Identifier	04	Function defined by serial ID
2	1	Connector	01	SC Receptacle
3	8	Transceiver	00,00,00,00,00,00,00,00	Not Supported
11	1	Encoding	03	NRZ encoding
12	1	Nominal Bit Rate in 100Mbps	19	2488.32 Mbps
13	1	Reserved	0	Reserved
14	1	Length (9μ,km) in km	14	20km
15	1	Length (9μ,m) in 100m	C8	20km
16	1	Length (50μ) in 10m	00	Not Supported
17	1	Length (62.5μ) in 10m	00	Not Supported
18	1	Length (Copper) in m	00	Not Supported
19	1	Reserved	00	Reserved
20	16	Vendor Name (ASCII)	XX	Vendor Name (ASCII)
36	1	Reserved	00	Reserved
37	3	Vender IEEE Company ID	00,00,00	IEEE ID
40	16	Vendor Part Number (ASCII)	XX	Vendor Part Number (ASCII)
56	4	Vendor Rev (ASCII)	31,20,20,20	Revision
60	2	Laser Wavelength in nm	05,D2	1490nm Tx Wavelength

62	1	Reserved	00	Reserved
63	1	Check Code for Base ID Fields	XX	Checksum from byte 0-62
64	2	Options	00,1C	TX_DIS, TX_Fault, SD
66	1	Upper Bit Rate Margin in %	00	Not specified
67	1	Lower Bit Rate Margin in %	00	Not specified
68	16	Vendor Serial Number(ASCII)	XX	Serial number field (ASCII)
84	8	Date Code	XX	YYMMDD0000
92	1	Diagnostic Monitoring Type	58	Ext Calibration, Average Power Measurement
93	1	Enhanced Options	E0	Optical Alarm/warning implemented Soft Tx_Dis, Tx_Fault implemented
94	1	SFF-8472 Compliance	02	Compliance to SFF-8472 Rev 9.5
95	1	Check Code for Extended ID Fields	XX	Checksum from byte 64-69
96	32	Vendor Specific	FF...FF	Vendor Specific
128	128	Reserved	FF...FF	Reserved; return to FF

## EEPROM Memory Map – Page A2h

Addr.(Dec)	Size(byte)	Name of field	Default Value(Hex)	Description
0	2	Temp High Alarm	55,00	85C
2	2	Temp Low Alarm	F1,00	-15C
4	2	Temp High Warning	50,00	80C
6	2	Temp Low Warning	F6,00	-10C
8	2	Voltage High Alarm	8C,A0	3.6V
10	2	Voltage Low Alarm	75,30	3.0V
12	2	Voltage High Warning	88,B8	3.5V
14	2	Voltage Low Warning	79,18	3.1V
16	2	Bias High Alarm	B9,8C	95mA
18	2	Bias Low Alarm	03,E8	2mA
20	2	Bias High Warning	A6,04	85mA
22	2	Bias Low Warning	05,DC	3mA
24	2	TX Power High Alarm	8A,99	+5.5 dBm
26	2	TX Power Low Alarm	2B,D4	+0.5dBm

28	2	TX Power High Warning	7B,87	+5.0dBm
30	2	TX Power Low Warning	31,2D	+1.0dBm
32	2	RX Power High Alarm	FF,FF	No alarm
34	2	RX Power Low Alarm	00,00	No alarm
36	2	RX Power High Warning	FF,FF	No alarm
38	2	RX Power Low Warning	00,00	No alarm
40	16	Reserved	00...00	Reserved
56	4	RX_PWR(4) Calibration	00,00	4th order RSSI calibration coefficient
60	4	RX_PWR(3) Calibration	00,00	3rd order RSSI calibration coefficient
64	4	RX_PWR(2) Calibration	00,00	2nd order RSSI calibration coefficient
68	4	RX_PWR(1) Calibration	3F,80	1st order RSSI calibration coefficient
72	4	RX_PWR(0) Calibration	00,00	0th order RSSI calibration coefficient
76	2	TX_I(Slope) Calibration	01,00	Slope for Bias calibration
78	2	TX_I(Offset) Calibration	00,00	Offset for Bias calibration
80	2	TX_PWR(Slope) Calibration	01,00	Slope for TX Power calibration
82	2	TX_PWR(Offset) Calibration	00,00	Offset for TX Power calibration
84	2	T(Slope) Calibration	01,00	Slope for Temperature calibration
86	2	T(Offset) Calibration	00,00	Offset for Temperature calibration, in units of 256ths C
88	2	V(Slope) Calibration	01,00	Slope for VCC calibration
90	2	V(Offset) Calibration	00,00	Offset for VCC calibration
92	3	Reserved	00,00,00	Reserved
95	1	Checksum	XX	Checksum
96	2	Transceiver Temperature	XX	Temperature in C/256
98	2	Supply Voltage	XX	Vcc
100	2	TX Bias Current	XX	BIASMON
102	2	TX Optical Output Power	XX	Back facet monitor
104	2	RX Optical Input Power	XX	RSSI
106	2	Reserved	00,00	Reserved
108	2	Reserved	00,00	Reserved
110.7	1bit	TX_DIS State	X	Digital state of the TX Disable InputPin.
110.6	1bit	Soft TX Disable Select	X	Read/write bit that allows software disable of laser.
110.5	1bit	Reserved.	0	Reserved.
110.4	1bit	Rate Select State	0	NOT SUPPORTED.
110.3	1bit	Soft Rate_Select Select	0	NOT SUPPORTED.



110.2	1bit	TX Fault State	X	Digital state of the TX Fault Output Pin.
110.1	1bit	Rx_LOS State	0	Digital state of the LOS Output Pin.
110.0	1bit	Data_Ready_Bar State	X	Indicates transceiver has achieved power up and data is ready.
111	1	Reserved	00	Reserved
112	1	Alarm and Warning Flag Bits	XX	Refer to SFF-8472 Table 3.18
113	1	Alarm and Warning Flag Bits	XX	Refer to SFF-8472 Table 3.18
114	1	Reserved	00	Reserved
115	1	Reserved	00	Reserved
116	1	Alarm and Warning Flag Bits	XX	Refer to SFF-8472 Table 3.18
117	1	Alarm and Warning Flag Bits	XX	Refer to SFF-8472 Table 3.18
118	1	Reserved	00	Interrupt Mask for ISRC2
119	1	Reserved	00	Interrupt Mask for ISRC3
120	8	Vendor Specific	00...00	Vendor specific memory addresses
128	128	Reserved	FF...FF	Reserved; return to FF

**Ordering Information**

Ordering P/Ns	Description
<b>CLGPONOLTB+</b>	GPON OLT B+, 20km, TX 1490nm 2.488Gbps, RX 1310nm 1.244Gbps, SFP, BIDI SC/UPC Receptacle, Commercial Temperature
<b>CLGPONOLTB+I</b>	GPON OLT B+, 20km, TX 1490nm 2.488Gbps, RX 1310nm 1.244Gbps, SFP, BIDI SC/UPC Receptacle, Industrial Temperature

**VERSION UPDATE:**

VERSION NO.	DATE	UPDATED INFORMATION
V20141213	20141213	1. Published

**NOTICE:**

C-LIGHT reserves the right to make changes to this product in this specification without notice, in order to improve product performance.

**CONTACT:**

Shenzhen C-Light network communication co., Ltd

4F East, Building 1, Shunheda Factory Plant, Liuxiandong industrial park,  
Xili, Nanshan Dist, Shenzhen

PR. China

**Tel:** 86-755-2778-9180    **Fax:** 86-755-2778-9174

**E-mail:** [sales@c-light.com](mailto:sales@c-light.com)    <http://www.c-light.com>